



Study and Sizing of Centrifugal Pumps: The Case of SOMAÏR's 2013 Pumps, North Niger

Ousman Mahamadou ^a, Maman Hassan Abdourazakou ^{b*},
Souley Harouna ^b and Illou Issoufa Souleymane ^a

^a Department of Electromechanics, School of Mines, Industry and Geology of Niamey (EMIG), Niger.

^b Department of Geosciences, School of Mines, Industry and Geology of Niamey (EMIG), Niger.

Authors' contributions

This work was carried out in collaboration among all authors. All authors read and approved the final manuscript.

Article Information

DOI: <https://doi.org/10.9734/ajopacs/2024/v12i3229>

Open Peer Review History:

This journal follows the Advanced Open Peer Review policy. Identity of the Reviewers, Editor(s) and additional Reviewers, peer review comments, different versions of the manuscript, comments of the editors, etc are available here: <https://www.sdiarticle5.com/review-history/121426>

Original Research Article

Received: 09/06/2024

Accepted: 13/08/2024

Published: 22/08/2024

ABSTRACT

The present study concerns the design and sizing of centrifugal pumps, the case of the 2013 pumps used at the Société des Mines de l'Air. The Société des Mines de l'Air (Somaïr), characterized by extensive modernization and industrialization, has increasingly new needs. The study began by analyzing the existing situation for each circuit. We then proceeded to size the pumps, choosing the type of pump and the material best suited to each type of circuit, taking into account the characteristics of the fluid being pumped. The suction and discharge head losses are 0.02434 m and 0.038 m respectively. The pump's hydraulic power is 10.806 kW. In view of the 18.5 kW mechanical power required for the drive motor, we have chosen 13.51 kW in order to keep within a reasonable margin. Thus, the pump has an absorbed power of 13.51 kW with an efficiency of 80%.

*Corresponding author: E-mail: abdourazakoum@gmail.com;

For the P3 2225 pump, the mechanical power is 2.4 kW, the HMT is 50 m, and the flow rate, speed and efficiency are 10 m³ /h, 2900 rpm and 60% respectively. For the P4 5154 pumps in the discharge circuit, the mechanical power of the pump is 6.42 KW, the HMT is 30 m and the flow, speed and efficiency are 50 m³ /h, 2900 rpm and 68% respectively.

Keywords: Wastewater transfer; centrifugal pumps; product sufficiency.

1. INTRODUCTION

Nowadays, wastewater transfer is a mastered technique, where the pumped product is sufficiently liquid to flow and therefore remains pumpable. Loaded water is any water containing various elements in suspension, ranging from earth, gravel and detritus to particles of metal or coal, whole fish, etc. This is why it is necessary to choose special pumps for this purpose. So it's essential to choose special pumps adapted to the type of activity. Any pump designed to convey a heterogeneous liquid must have sufficiently wide internal passage cross-sections and an impeller that offers the minimum number of obstacles to the circulation of this liquid, to avoid clogging or obstruction [1]. There are several types of pump, including sewage pumps, pumps for abrasive liquids and pumps for corrosive liquids. Sewage is essentially a mixture of runoff and wastewater. It can contain all kinds of products with different chemical properties, as well as detritus of sometimes large dimensions and particulate forms: rags, leaves, organic waste, etc. [2]. They comprise a minimum of two pumps, one of which is an emergency pump that can provide additional flow at peak times. The pumping stations designed to discharge these effluents are generally underground or below ground level, and are equipped with wastewater pumps [3]. The materials contained in the abrasive liquid are often very fine and barely visible, but can sometimes be of a larger granulometry. However, it has been proven that a pump conveying such a mixture will wear out more or less quickly, resulting in a drop in characteristics (flow-pressure), an increase in energy consumption and an abnormal and increased frequency of maintenance [4]. In general, centrifugal pumps working in abrasive environments have fairly large flow cross-sections to avoid excessively high flow velocities. This is why pumps for abrasive liquids are used. They are fitted with wear parts at carefully chosen points, which can be easily dismantled and replaced if necessary to restore the pump's efficiency and performance. Pumps for corrosive liquids are used in the chemical, pharmaceutical, nuclear and petrochemical industries. For

chemical corrosion, the pH of the liquid must be taken into account [5]. Knowledge of this pH will determine, among other things, the choice of material or the type of protection to be envisaged. Even today, the design of centrifugal and helical centrifugal pumps, based on an experimental and statistical approach, remains empirical in many respects [6]. The design of these machines, where significant mechanical, thermal or hydraulic energy exchanges take place, follows various stages ranging from mechanical and hydraulic predimensioning, to the fine analysis of internal flows [7].

The present study concerns the design and sizing of centrifugal pumps, the case of the 2013 pumps used at the Société des Mines de l'Air. The Société des Mines de l'Air (Somair), characterized by extensive modernization and industrialization, has increasingly new needs. The need to ramp up production is forcing Somair to innovate its production process. The company uses several types of pumps, including centrifugal pumps, to pump and evacuate fluids from the various processes involved in uranate production. Pumps are essential elements in the life and comfort of human beings [8]. Pumps are devices for transferring energy between a fluid and a suitable mechanical device. A centrifugal pump is a rotating machine designed to impart sufficient energy to the liquid being pumped to cause it to move through a hydraulic network, generally involving a geometric height, a pressure rise and always pressure losses. A centrifugal pump consists mainly of an impeller with blades or vanes that rotates inside a sealed casing called the pump body [9,10]. The ejector solar thermal refrigerant system is suitable for high flow, low pressure and large size applications, while the centrifugal pump/PV system is preferred for medium head, medium flow and medium installed cost applications [11]. The operation of multistage pumps transporting water from the source to the delivery point requires balancing of the pressure at the junction of the pump and pipeline according to their characteristics [12]. Centrifugal pumps have a wide range of applications in the fields of industrial and municipal water. When using

centrifugal pumps, failures such as bearing wear, blade damage, impeller imbalance, shaft misalignment, cavitation, water hammer, etc. often occur [13]. Sizing a hydraulic installation has always been a delicate task, especially in a mining complex such as Somair. In the course of this work, the techniques and itineraries used to propose solutions to the problems involved were elucidated. In fact, this study enabled us to appreciate the difficulties associated with the choice of pumps, the space required to calculate the HMT and NPSH, and even better, the ISO of the hydraulic circuits.

To carry out this work, the study will first analyze the existing situation for each circuit. Next, we'll size the pumps, choosing the type of pump and the material best suited to each type of circuit, taking into account the characteristics of the fluid being pumped.

2. MATERIALS AND METHODS

2.1 Presentation of the Study Area

The town of Arlit is located in the Agadez region, between latitudes 18° 24' 22" N and 21° 11' 03" N and meridians 5° 47' 54" E and 8° 02' 28" E (Fig. 1). The town is located in the arid, hot and dry northern desert region of the Republic of Niger. This commune, in which our study area is located, is bordered to the east by the rural commune of Iférouane, to the west by the rural commune of In Gall, to the south by the rural commune of Dannat, to the southeast by the rural commune of Gougaram and to the north by Algérie: Cité Somair, Zongo, Wadata, Sahel, Tamesna, Boukoki Tanesna, Boukoki Sud, Boukoki Est, Carré SNTN, Carré Nouveau Marché, Compagnie Madawela, Cité Akokan, Akokan Carré, Quartier Administratif and Takriss [14]. The population of this commune was estimated at 99,000 in 2007, including 28,000 in the mining towns and 71,000 in the induced towns [15]. In 2018, the town had a population of over 200,000 as a result of demographic growth. Arlit is located in the Saharan zone, which covers 77% of the country, where average annual rainfall is less than 150 mm. The region is a dry, hot desert, characterized by an average annual temperature ranging from around 15°C to 35°C, with an average of 28°C. Maximum temperatures can exceed 40°C from March to October and approach 45°C from May to July. Nights are generally cool during the cold season, with temperatures below 20°C. The hottest months of the year are May and June, with an average of

34.2°C during this period. The coolest temperatures are observed in January with an average temperature of 18.8°C [16,17,18].

HMT calculation:

At a given flow rate, the minimum energy required to overcome the pressure forces and frictional losses between the suction and discharge points in order to lift the fluid from one point to another is called the HMT required. This energy is expressed in mCL, by the following Bernoulli equation applied between two points A and B:

$$P_A / \rho g + Z_A + V_A^2 / 2g + HMT = P_B / \rho g + Z_B + V_B^2 / 2g + \Sigma \Delta P \text{ where}$$

$\Sigma \Delta P$: total pressure drop in meters (m) ;
 P_A , P_B : respectively pressures at suction point (A) and discharge point (B) in Pascals (Pa);
 V_A , V_B : respective velocities at intake point (A) and discharge point (B) in m/s ;
 ρg : specific gravity in N/kg ;
 Z_A , Z_B : respectively the dimensions of the suction point (A) and discharge point (B).
 $P_A / \rho g + Z_A + V_A^2 / 2g + HMT = P_B / \rho g + Z_B + V_B^2 / 2g + \Sigma \Delta P$
 $\Rightarrow HMT = (P_A - P_B) / \rho g + (Z_A - Z_B) + (V_A^2 - V_B^2) / 2g + \Sigma \Delta P$ (m).

In fact, in a simpler way and depending on whether the pump is in load or suction mode, the HMT is determined by the following formulas:

❖ Pump under load :

A pump is loaded when the minimum level of the fluid drawn in is above the pump's reference plane.

$$HMT = H_r - H_c + \Sigma \Delta P$$

❖ Suction pump :

A pump is in suction mode when its reference plane is above the minimum level of the fluid being pumped.

$$HMT = H_r + H_a + \Sigma \Delta P$$

Calculating pressure losses:

Any fluid flowing through a pipe loses its initial pressure with every meter it travels, and every time it passes a singularity. This is because the internal surface of pipes has a considerable degree of roughness, which, as the fluid flows, generates friction losses. Obstacles such as elbows, tees, narrowings and sudden widenings also result in energy losses.

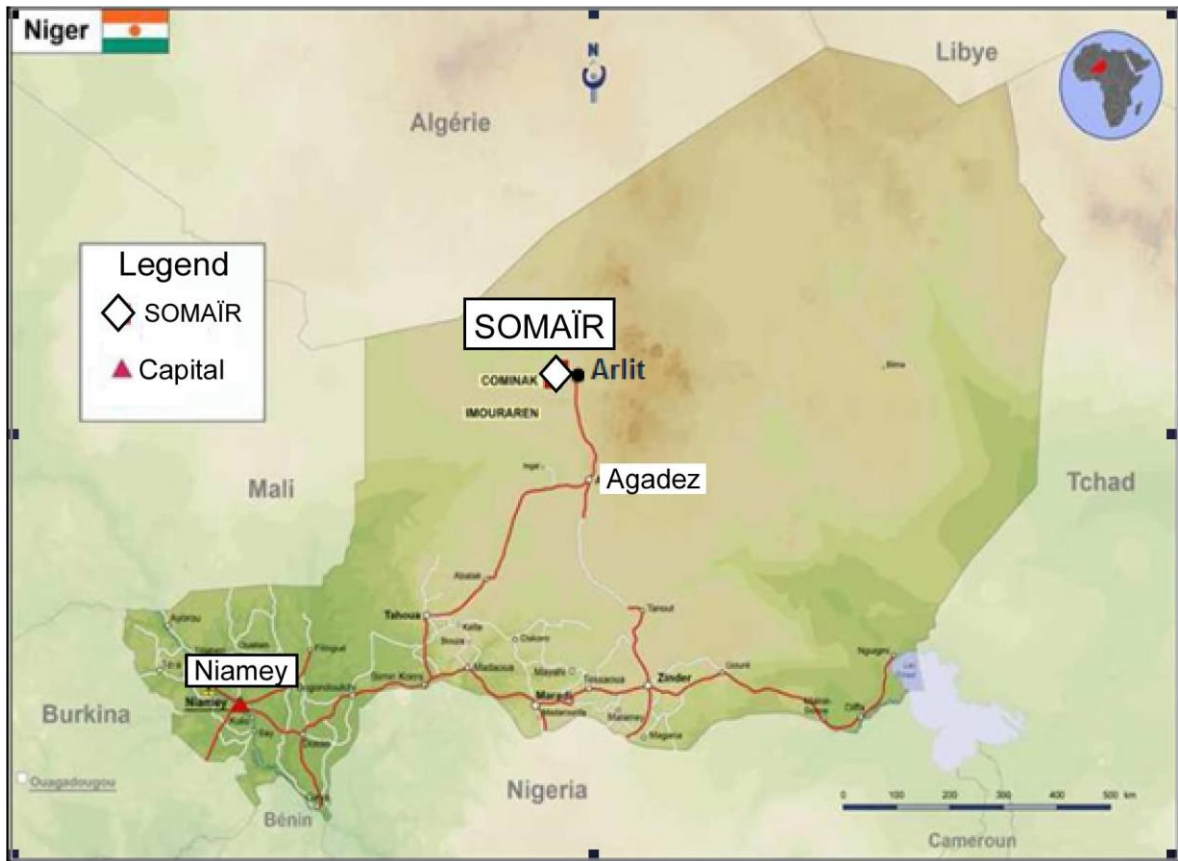

Fig. 1. Study area

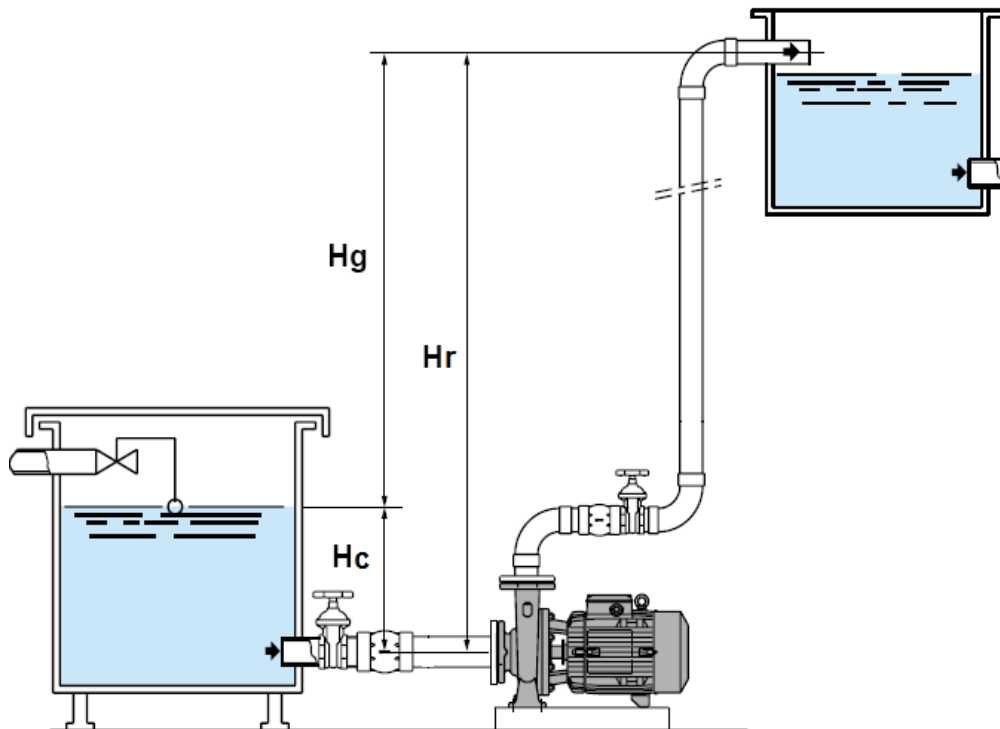

Fig. 2. Load pump assembly

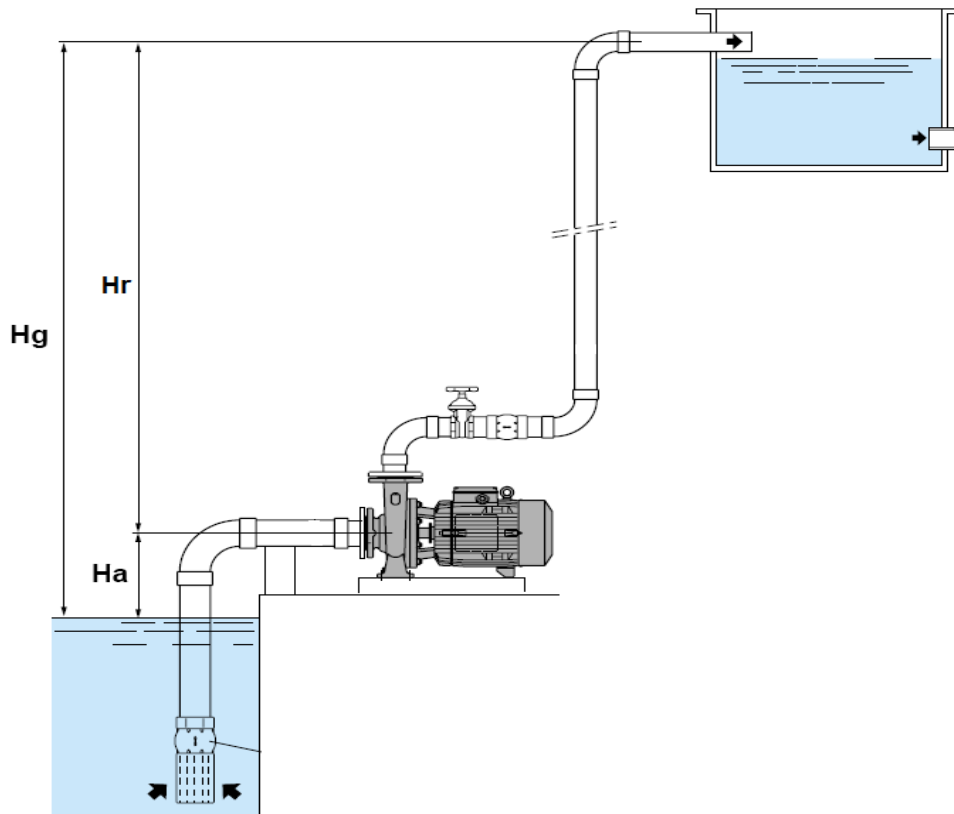

Fig. 3. Suction pump assembly

There are therefore two types of pressure loss:

- Head losses due to the length of the pipes, known as linear, regular or systematic losses;
- And singular pressure drops.

Calculating regular pressure losses:

The regular head losses are due to the length of the pipe and are given by the following formula:

$$\Delta H = \lambda \cdot \frac{l}{d} \cdot \frac{v^2}{2g} \text{ (m)}.$$

- ΔH : linear head losses (m) ;
- d : pipe diameter (m) ;
- V : average flow velocity in the pipe (m/s) ;
- l : total pipe length (m) ;
- g : acceleration of gravity (m/s²) ;
- λ : linear pressure loss coefficient (s.d).

Calculating singular losses:

As opposed to linear head losses, which are proportional to the length of the pipe, singular head losses are caused by singularities.

These peculiarities are most often bends or abrupt deviations, tees, abrupt narrowings or widenings, flow and pressure control devices, etc.

Singular head losses are given by the following formula:

$$\Delta H = \xi \frac{v^2}{2g} \text{ (m)}$$

- ΔH : singular pressure drop in m.
- ξ : pressure loss coefficient (s.d), depends on the nature and geometry of the "accident". It is given in the manufacturer's catalogs;
- V : velocity in the pipe with the smallest cross-section in m/s ;
- g : acceleration of gravity in m²/s .

Calculating NPSH:

A pump has a maximum suction capacity, which is the amount of vacuum it can produce. This characteristic varies according to the type and technical design of the pump.

The required NPSH is provided by the manufacturer. It is generally given in the form of a curve as a function of flow rate, on the same graph as the HMT curve. Its values are a few meters of liquid column. Some pumps have a very low NPSH requirement, in order to limit the risk of cavitation in certain suction installations (Fig. 4).

The required NPSH is the minimum available NPSH that the pump must have to avoid cavitation. This is because static pressure drops between the pump inlet (suction flange) and the impeller inlet, notably due to the acceleration of the pumped fluid (part of the static pressure is thus transformed into speed).

For a pump to operate normally (without cavitation), the available NPSH (calculated) must be greater than the required NPSH (given by the manufacturer).

$$NPSH_{available} > NPSH_{required}$$

If the required NPSH value is not reached, degassing and then partial vaporization of the liquid will occur inside the pump. Consequences range from a drop in system pressure to impeller damage caused by the presence of bubbles.

When the $NPSH_{available}$ is lower than the $NPSH_{required}$, the pump cavitates. In a centrifugal pump, cavitation is the vaporization of part of the pumped liquid at the impeller inlet. This is where the pressure is generally (but not always) lowest.

Vaporization is generally considered to occur when the static pressure falls below the saturation vapour pressure of the fluid being pumped. In reality, it is sometimes due to the creation of bubbles of gas dissolved in the liquid (particularly in the case of water), in which case we speak of apparent cavitation.

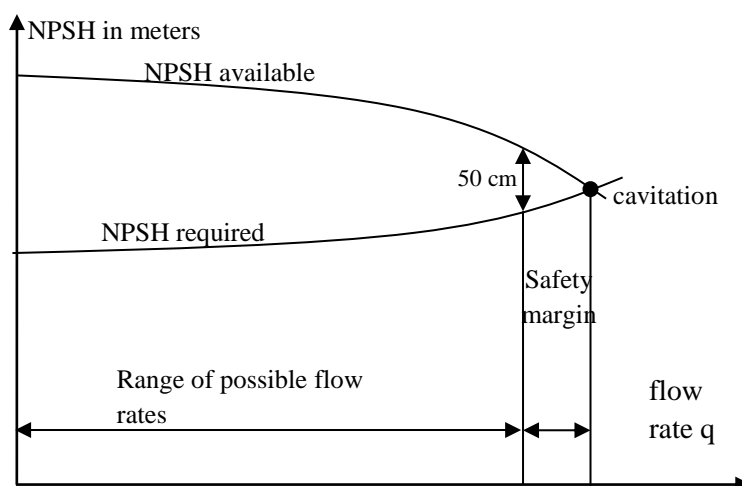

Fig. 4. Practical NPSH curves

3. RESULTS AND DISCUSSION

3.1 Pump Sizing P3 2224

As the suction pipes are horizontal, the reference plane of the pumps coincides with the pipe axis, so these pumps are under load.

3.2 HMT Calculation

At a given flow rate, the minimum energy required to overcome the pressure forces and frictional losses between the suction and discharge points in order to lift the fluid from one point to another is called the HMT required. A pump is loaded when the minimum level of the fluid drawn in is above the pump's reference plane. To calculate the HMT of these pumps, we took direct measurements on the installations and then produced an isometric diagram of the circuit. The isometric diagram gives us the following values:

Hr = 19.12 m ;
Hc = 0.9 m.

Pressure loss values:

They are of two types:

- Head losses due to the length of the pipes, known as linear, regular or systematic losses;
- And singular pressure drops.

3.3 Determining Linear Load Values

The P3 2224 circuit has the following characteristics:

- The suction pipes are made of steel and have a diameter of 300 mm over a length of $L_1 = 10$ m and a diameter of 200 mm over a length of $L_2 = 2.332$ m.

For $l_1 = 10$ m ; $D_1 = 300$ mm ;

$Q = 175$ m³ /h; $\nu = 0.556 \cdot 10^{-6}$ m² /s for water at 50°C .

$$V = \frac{Q}{S} = \frac{4 \cdot Q}{\pi \cdot D^2} \Rightarrow V_1 = \mathbf{0.68 \text{ m/s}}.$$

Reynolds number calculation: $Re = \frac{V \cdot D}{\nu}$

V: average fluid velocity (m/s) ;

D: pipe diameter (m) ;

ν : absolute kinematic viscosity (m²/s).

$Re = \frac{V \cdot D}{\nu} = \mathbf{370.909} > \mathbf{10^5} \Rightarrow$ it's a rough turbulent flow.

For an industrial pipe, the pressure loss coefficient λ is given by the BLENCH formula:

$\lambda = 0,79 \sqrt{\frac{\epsilon}{D}}$ with ϵ : conventional or average roughness = 0.045 mm for steel.

D: pipe diameter (m).

$$\lambda = 0,79 \sqrt{\frac{\epsilon}{D}} = 9,6 \cdot 10^{-3}$$

$$\Delta H_1 = \lambda \cdot \frac{L}{d} \cdot \frac{V^2}{2g} = 0,00754 \text{ m}.$$

For $l_2 = 2.332$ m; $D_2 = 200$ mm; $Q = 175$ m³ /h; $\nu = 0.556 \cdot 10^{-6}$ m /s²

$$V = \frac{Q}{S} = \frac{4 \cdot Q}{\pi \cdot D^2} \Rightarrow V_2 = 1.55 \text{ m/s}.$$

$Re = \frac{V \cdot D}{\nu} = \mathbf{557.553} > \mathbf{10^5} \Rightarrow$ it 's a rough turbulent flow.

$$\lambda = 0,79 \sqrt{\frac{\epsilon}{D}} = 0,0118$$

$$\Delta H_2 = \lambda \cdot \frac{L}{d} \cdot \frac{V^2}{2g} = 0,0168 \text{ m}.$$

The total regular suction head losses are: $\Delta H_1 + \Delta H_2 = \mathbf{0.02434}$ m.

The discharge section has the following characteristics:

This circuit raises industrial water to the P3 2225 pumps via a stainless steel pipe 30.08 m long and 200 mm in diameter.

For $L_3 = 29.08$ m; $D = 200$ mm; $Q = 175$ m³ /h; $\nu = 0.556 \cdot 10^{-6}$ m /s²

$$V = \frac{Q}{S} = \frac{4 \cdot Q}{\pi \cdot D^2} \Rightarrow V_1 = 1.55 \text{ m/s}.$$

$Re = \frac{V \cdot D}{\nu} = 557.553 > 10^5 \Rightarrow$ it's a rough turbulent flow.

$$\lambda = 0,79 \sqrt{\frac{\epsilon}{D}}$$

$\epsilon = 0.0015$ mm for a stainless steel pipe.

$$\lambda = 0,79 \sqrt{\frac{\epsilon}{D}} = 2,16 \cdot 10^{-3}$$

$$\Delta H_3 = \lambda \cdot \frac{L}{d} \cdot \frac{V^2}{2g} = 0,038 \text{ m}.$$

Table 1. Summary of regular losses

Regular losses	Values in m
Vacuum	0,02434
Backflow	0,038

3.4 Determining the NPSH Value

A pump has a maximum suction capacity, which is the amount of vacuum it can produce. This characteristic varies according to the type and technical design of the pump (Fig. 5).

The calculation of the available NPSH depends on the pump installation.

For a pump under load:

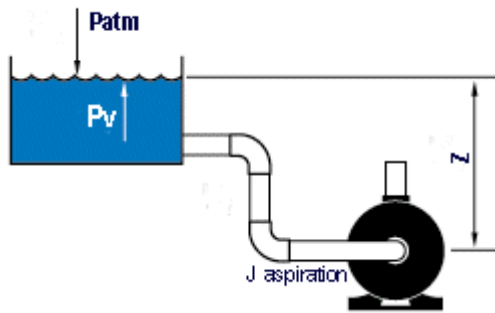

Fig. 5. Pump under load

$$NPSH(m) = Patm - Pv - \Delta Pasp + PHh$$

For a suction pump (Fig. 6) :

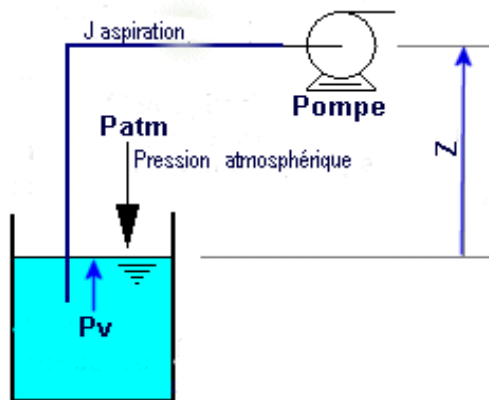

Fig. 6. Suction pump

$$NPSH(m) = Patm - Pv - \Delta Pasp - PHh$$

Patm = Atmospheric pressure (altitude-dependent) in m ;

Pv = Absolute vaporization pressure (m) of the fluid ;

$\Delta Pasp$ = Pressure drop in suction line in m ;

PHh = $(9.81 * Z * \rho)$ Hydraulic fluid load in m.

In the case of this study, we're talking about a pump under load. In practice, we must always have :

$$10 - (Hc + \Delta Pasp) \geq NPSH_{required} \Rightarrow NPSH_{available} = 10 - (Hc + \Delta Pasp)$$

$$\Rightarrow NPSH_{available} = 10 - (0.9 + 1.126)$$

$$\Rightarrow NPSH_{available} = 7.97 \text{ m}$$

3.5 Power Calculation

Now that we know the pump parameters, we need to determine the pump's hydraulic power. This power will finally lead us to the power of the drive motor (Fig. 7).

3.6 Hydraulic Pump Power

This is the power supplied by the pump and absorbed by the fluid to set it in motion. It is given by the following formula:

$$P_{hyd} = \rho \cdot g \cdot HMT \cdot Q$$

$$\rho = 1.05 \cdot 10^3 \text{ kg/m}^3 ; HMT = 21.58 \text{ m} ; Q = 175 \text{ m}^3 / \text{h} ; g = 9.81 \text{ m/s}.$$

$$AN: P_{hyd} = 10,806 \text{ W or } P_{hyd} = 10.806 \text{ kW}.$$

3.7 Mechanical Power Absorbed by the Pump

This is the power measured on the shaft. The mechanical energy required by a pump is always greater than the energy transmitted to the fluid, as a result of friction between the rotating parts.

Permissible centrifugal pump efficiencies range from 0.6 to 0.85.

In view of the 18.5 kW power requirement for the drive motor, we chose 13.51 kW in order to remain within an appreciable margin. Thus, the pump has an absorbed power of 13.51 kW with an efficiency of 80%.

Table 2. Classification of parameters influencing available NPSH and cavitation

Increased risk of cavitation	Reduced risk of cavitation
Increased suction temperature (higher saturation vapour pressure)	lower suction temperature
reduced suction pressure	Increased suction pressure
High suction pressure drop (filter clogged, valve partially closed)	
drop in the level of the pumped fluid if it is a suction installation (well, river, etc.)	increase in pumped fluid level
Increased flow (increased suction pressure drop)	flow reduction

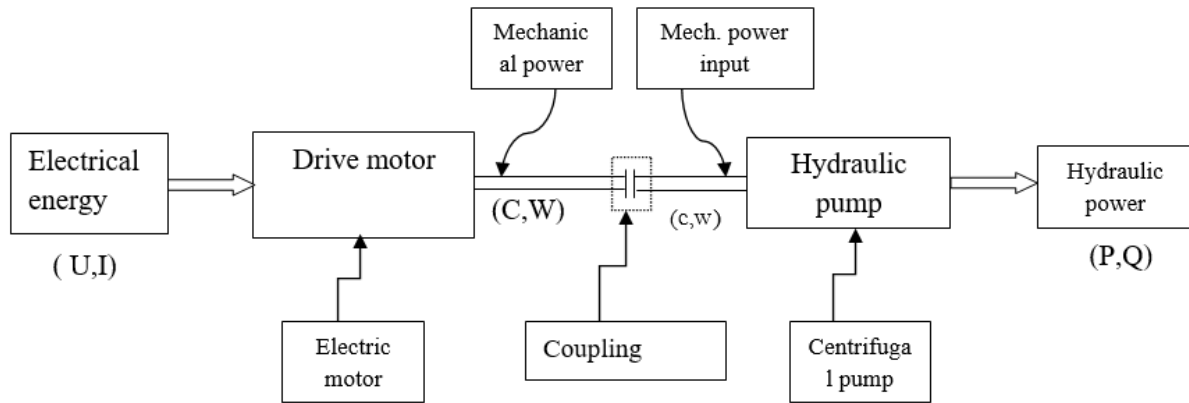

Fig. 7. Schematic diagram

Table 3. Mechanical efficiency and power

η_{pompe}	0,6	0,78	0,8
$P_{méc.}$ (kW)	18,01	14,408	13,51

Table 4. Summary of pump features

$P_{méc.}$ (kW)	13,51
HMT (m)	21,58
Flow rate (m ³ /h)	175
Speed (rpm)	1450
Yield η	80%

3.8 Drive Motor Power

When choosing a motor, the power absorbed by the pump determines the power delivered by the motor, and therefore also the power absorbed by the mains. Care must therefore be taken to ensure that the motor has sufficient power to satisfy all system operating conditions. To calculate this power, we don't have the coupling's transmission ratio. By projecting the power absorbed by the pump onto the curve, we obtain the coefficient to be applied to obtain the corresponding motor power. Thus, our installed power is :

$$P_{inst} = 118\% P_{méc} \Rightarrow P_{inst} = 15.94 \text{ kW.}$$

Pump sizing P3 2225

These pumps draw in the industrial water discharged by pumps P3 2224 and raise it to an altitude of around 20 m.

The isometric diagram shows the details of the circuit.

★ Operator data

The pumped water has the following characteristics:

$T = 50^\circ\text{C}$
 Density = 1.05
 pH = 7.8
 flow $Q = 10 \text{ m}^3/\text{h}^3$

★ HMT

Pressure loss calculations are not necessary as the HMT is already given, but if required, they will be calculated.

$$NPSH \quad \boxed{HMT = 50 \text{ m}}$$

P3 2225 pumps are suction-mounted, so their NPSH is given by the following formula:

$$NPSH_{available} = 10 - (H_a + \Delta P_{asp})$$

To determine this NPSH, we first calculate the suction losses.

Suction pipes have the following characteristics:

4 90° bends $\Rightarrow \xi = 1.5 \times 4$;
 a valve $\Rightarrow \xi = 3$
 narrowing $\Rightarrow \xi = 1.5$
 a flange $\Rightarrow \xi = 1.5$
 Length $l = 2.583 \text{ m}$ in steel; $\epsilon = 0.045 \text{ mm}$;
 $D = 40 \text{ mm}$;

$H_a = 1.92 \text{ m}$;

– Regular losses :

$$V = \frac{Q}{S} = \frac{4 \cdot Q}{\pi \cdot D^2} \Rightarrow V_1 = 2.21 \text{ m/s.}$$

$Re = \frac{V \cdot D}{\nu} = 158.992,8 > 10^5 \Rightarrow$ rough turbulent flow.

$$\lambda = 0,79 \sqrt{\frac{\varepsilon}{D}} = 2.65 \cdot 10^{-2}.$$

$$\Delta H = \lambda \cdot \frac{l}{d} \cdot \frac{v^2}{2g} = 0,425 \text{ m.}$$

– Singular losses :
 $\sum \xi = 12$

$$\Delta H = \frac{\xi V^2}{2g} = 2,987 \text{ m.}$$

$$\Delta P_{asp} = 0.425 + 2.987 \Rightarrow \Delta P_{asp} = 3.412 \text{ m ;}$$

$$NPSH_{available} = 10 - (1.92 + 3.412) \Rightarrow NPSH_{available} = 4.668 \text{ m}$$

★ Choice of material

The characteristics of the fluid lead us to choose **spheroidal graphite cast iron (Fonte GS)** as the material to be used for pump construction.

★ Pump selection

The discharge flange has a measured diameter of 140 mm, which corresponds to a 32 mm pipe.

With a HMT of 50 m and a flow rate of 10 m³ /h, the diagram gives us by projection, the pump:

★ Power calculation

50 - 32 CPX 200

❖ Hydraulic pump power

$$P_{hyd} = \rho \cdot g \cdot HMT \cdot Q$$

$\rho = 1.05 \cdot 10^3 \text{ kg/m}^3$; $HMT = 50 \text{ m}$; $Q = 10 \text{ m}^3 / \text{h}$;
 $g = 9.81 \text{ m/s}$.

AN: $P_{hyd} = 1430.625 \text{ W}$ or $P_{hyd} = 1.43 \text{ kW}$.

Table 5. Mechanical power of the pump

η_{pompe}	0,6	0,78	0,8
$P_{méc.} \text{ (kW)}$	2,4	1,83	1,78

To stay within the imposed power margin, we have chosen a power of 2.4 kW.

Table 6. Summary of pump features

$P_{méc.} \text{ (kW)}$	2,4
HMT (m)	50
Flow rate (m ³ /h) ³	10
Speed (rpm)	2900
Yield η	60%

❖ Drive motor power

Knowing the power absorbed by the pump, by projection on the curve, we obtain the coefficient to be applied in order to obtain the corresponding motor power. Thus, our installed power is:

$$P_{inst} = 135\% P_{méc} \Rightarrow P_{inst} = 3.24 \text{ kW}$$

We will now refer to the catalog to select a standardized power

Finally, the pump motor is rated at 4 kW.

The precipitation circuit

This circuit is made up of two groups of pumps: P4 5134 A - C pumps and P4 5154 A - C pumps. They all convey the same fluid, with a temperature of 60°C, a specific gravity of 1.07 and a pH of 2.5.

Pump sizing P4 5154

These pumps draw from the S2 5153 tank and discharge into the solo tank. The fluid conveyed is not very viscous, but it is an aggressive acid, which calls for a judicious choice of materials in the manufacture of the equipment that will make up this circuit.

★ Operator data

The fluid pumped is uranyl sulfate, whose characteristics are as follows:

T= 60°C

Density= 1.07

pH= 2.5

a flow rate Q = 50 m³ /h.³

★ HMT

the HMT is already given,

$$HMT = 30 \text{ m}$$

★ NPSH

P4 5154 pumps are mounted under load, so their NPSH is given by the following formula:

$$NPSH_{available} = 10 - (H_c + \Delta P_{asp})$$

To determine this NPSH, we first calculate the suction losses.

Suction pipes have the following characteristics:

3 90° bends => $\xi = 1.5 \times 3$;
 a valve => $\xi = 3$
 a flange => $\xi = 1.5$
 Length $l = 2.64$ m in stainless steel; $\epsilon = 0.0015$ mm ;
 $D = 90$ mm ;

Hc = 1.2 m ;

– Regular losses :

$$V = \frac{Q}{S} = \frac{4.Q}{\pi.D^2} \Rightarrow V_1 = 2.18 \text{ m/s.}$$

Assumption: As we do not have a viscometer, we consider the viscosity of water at 20°C for sizing purposes:

$$\nu = 10^{-6} \text{ m}^2/\text{s}^2$$

$$Re = \frac{V.D}{\nu} = 196.200 > 10^5 \Rightarrow \text{rough turbulent flow.}$$

$$\lambda = 0,79 \sqrt{\frac{\epsilon}{D}} = 1.02 \cdot 10^{-1}$$

$$\Delta H = \lambda \cdot \frac{l}{d} \cdot \frac{V^2}{2g} = 0,725 \text{ m}$$

– Singular losses :
 $\sum \xi = 9$

$$\Delta H = \frac{\xi V^2}{2g} = 2,18 \text{ m}$$

$$\Delta P_{asp} = 0.725 + 2.18 \Rightarrow \Delta P_{asp} = 2.905 \text{ m ;}$$

$$NPSH_{available} = 10 - (1.2 + 2.905) \Rightarrow NPSH_{available} = 5.895 \text{ m}$$

★ Choice of material

As the fluid is acidic, it necessarily requires an acid-resistant material, and all the metals generally used in pump manufacture can be attacked by acids. With a temperature of 60°C and a pH = 2.5, we chose a **nickel-chromium steel** pump, specifically **X2CrNiMo 17-12-2**. This stainless steel is highly resistant to azotic and organic acids.

Pump selection

The discharge flange has a measured diameter of 220 mm, which corresponds to an 80 mm pipe.

With a HMT of 30 m and a flow rate of 50 m³ /h, a speed of 2900 rpm, the diagram gives us, by projection, the pump:

100 - 80 CPX 125

Power calculation

❖ Hydraulic pump power

$$P_{hyd} = \rho.g.HMT.Q$$

$$\rho = 1.07 \cdot 10^3 \text{ kg/m}^3 ; HMT = 30 \text{ m} ; Q = 50 \text{ m}^3 / \text{h} ; g = 9.81 \text{ m/s.}$$

$$AN: P_{hyd} = 4,373.62 \text{ W or } P_{hyd} = 4.37 \text{ kW.}$$

❖ Mechanical power of the pump

To stay within the required power margin, we have chosen a power of 6.42 kW.

Table 7. Summary of pump features

P_{méc.} (kW)	6,42
HMT (m)	30
Flow rate (m³ /h)	50
Speed (rpm)	2900
Yield η	68%

The mechanical power of the pump selected is 6.42 KW, the HMT is 30 m and the flow rate, speed and efficiency are 50 m³ /h, 2900 rpm and 68% respectively.

❖ Drive motor power

Knowing the power absorbed by the pump, by projection on the curve, we obtain the coefficient to be applied in order to obtain the corresponding motor power. Thus, our installed power is:

$$P_{inst} = 125\% P_{méc} \Rightarrow P_{inst} = 8.025 \text{ kW}$$

We will now refer to the catalog to select a standardized wattage.

Finally, the pump motor is rated at 9 kW.

Pump sizing P4 5134

These pumps draw the uranyl sulfate from the tank into precipitation 2. This transfer is carried out by two pumps connected in parallel. As with the P4 5154, special care must be taken in the choice of materials used to manufacture the equipment making up the circuit.

★ Operator data

The fluid pumped is uranyl sulfate, whose characteristics are as follows:

T= 60°C
 Density= 1.07
 pH= 2.5
 a flow rate Q = 45 m³/h.

★ **HMT**

the HMT is already given.

$$\boxed{\text{HMT} = 18 \text{ m}}$$

★ **NPSH**

P4 5134 pumps are mounted under load, so their NPSH is given by the following formula:

$$\text{NPSH}_{\text{available}} = 10 - (\text{Hc} + \Delta\text{P}_{\text{asp}})$$

To determine this NPSH, we first calculate the suction losses.

Suction pipes have the following characteristics:

2 90° elbows => $\xi = 1.5 \times 2$;
 2 valves => $\xi = 3 \times 2$
 Length l = 2.5 m in stainless steel; $\epsilon = 0.0015$ mm ;

D = 90 mm ;

Hc = 1 m ;

– Regular losses :

$$V = \frac{Q}{S} = \frac{4.Q}{\pi.D^2} \Rightarrow V_1 = 1.96 \text{ m/s.}$$

As we do not have a viscometer, we consider the viscosity of water at 20°C for sizing purposes:

$$\nu = 10^{-6} \text{ m}^2/\text{s}^2$$

$\text{Re} = \frac{V.D}{\nu} = 176.400 > 10^5 \Rightarrow$ rough turbulent flow.

$$\lambda = 0,79 \sqrt{\frac{\epsilon}{D}} = 4.2 \cdot 10^{-2}$$

$$\Delta\text{H} = \lambda \cdot \frac{l}{d} \cdot \frac{V^2}{2g} = 0,29 \text{ m}$$

– Singular losses :
 $\sum \xi = 9$

$$\Delta\text{H} = \frac{\xi V^2}{2g} = 1,76 \text{ m}$$

$$\Delta\text{P}_{\text{asp}} = 0.29 + 1.76 \Rightarrow \Delta\text{P}_{\text{asp}} = 2.05 \text{ m ;}$$

$$\text{NPSH}_{\text{available}} = 10 - (1 + 2.05) \Rightarrow \text{NPSH}_{\text{available}} = 6.95 \text{ m}$$

★ **Choice of material**

As the fluid is acidic, with a temperature of 60°C and a pH = 2.5, we have chosen a **stainless steel X2CrNiMo 17-12-2** pump.

★ **Pump selection**

The discharge flange has a measured diameter of 220 mm, which corresponds to an 80 mm pipe.

With a HMT of 18 m and a flow rate of 50 m³/h, a speed of 2900 rpm, the diagram gives us by projection, the pump :

$$\boxed{100 - 80 \text{ CPX } 125}$$

★ **Power calculation**

❖ Hydraulic pump power

$$\boxed{P_{\text{hyd}} = \rho \cdot g \cdot \text{HMT} \cdot Q}$$

$$\rho = 1.07 \cdot 10^3 \text{ kg/m}^3 ; \text{HMT} = 18 \text{ m} ; Q = 45 \text{ m}^3/\text{h} ; g = 9.81 \text{ m/s.}$$

$$\text{AN: } P_{\text{hyd}} = 2,361.75 \text{ W or } P_{\text{hyd}} = 2.36 \text{ kW.}$$

❖ Mechanical power of the pump

η_{pompe}	0,6	0,7	0,8
P_{méc.} (kW)	3,93	3,37	2,95

To stay within the imposed power margin, we have chosen a power of 3.37 kW.

Table 8. Summary of pump features

P _{méc.} (kW)	3,37
HMT (m)	18
Flow rate (m ³ /h)	45
Speed (rpm)	2900
Yield η	70%

❖ Drive motor power

Knowing the power absorbed by the pump, by projection on the curve, we obtain the coefficient to be applied in order to obtain the corresponding motor power. Thus, our installed power is :

$$P_{\text{inst}} = 127.5\% P_{\text{méc}} \Rightarrow P_{\text{inst}} = 4.3 \text{ kW}$$

We will now refer to the catalog to select a standardized power.

Finally, the pump motor is rated at 5.5 kW.

The Precipitation circuit:

It consists of pumps P3 5124 A - C and P3 5125 A - B - C. The former draw water from a tank located one metre above sea level and discharge it into another located around seven metres above sea level. They convey uranyl sulfate at 60°C, with a pH = 2.5 and a density of 1.07. The second sucks water from a tank on the ground and pumps it to another at a height of around eight meters. These carry carbonate filtrate at 60°C, pH = 14 and density 1.06.

Pump sizing P3 5124:

As with the pumps in the previous circuit, P3 5124 pumps circulate a highly acidic fluid, which has consequences for the components that make up the circuit. A decisive choice must therefore be made as to the materials used to manufacture these components.

★ Operator data

The fluid pumped is uranyl sulfate, whose characteristics are as follows:

T= 60°C

Density= 1.07

pH= 2.5

a flow rate Q = 120 m³ /h.

★ HMT

the HMT is already given.

HMT = 18 m

★ NPSH

P3 5124 pumps are mounted under load, so their NPSH is given by the following formula:

$$NPSH_{available} = 10 - (H_c + \Delta P_{asp})$$

To determine this NPSH, we first calculate the suction losses.

Suction pipes have the following characteristics:

4 90° bends => $\xi = 1.5 \times 4$;

3 valves => $\xi = 3 \times 3$

Length l = 13 m in stainless steel; $\epsilon = 0.0015$ mm ;

D = 150 mm ;

Hc = 1 m ;

– Regular losses :

$$V = \frac{Q}{S} = \frac{4.Q}{\pi.D^2} \Rightarrow V_1 = 2.95 \text{ m/s.}$$

As we do not have a viscometer, we consider the viscosity of water at 20°C for sizing purposes:

$$\nu = 10^{-6} \text{ m}^2/\text{s}$$

$Re = \frac{V.D}{\nu} = 354.000 > 10^5 \Rightarrow$ this is turbulent rough flow.

$$\lambda = 0,79 \sqrt{\frac{\epsilon}{D}} = 4.2 \cdot 10^{-2}$$

$$\Delta H = \lambda \cdot \frac{l}{d} \cdot \frac{V^2}{2g} = 1,61 \text{ m}$$

– Singular losses :
 $\Sigma \xi = 15$

$$\Delta H = \frac{\xi V^2}{2g} = 6,65 \text{ m}$$

$$\Delta P_{asp} = 1.61 + 6.65 \Rightarrow \Delta P_{asp} = 8.26 \text{ m ;}$$

$$NPSH_{available} = 10 - (1 + 8.26) \Rightarrow NPSH_{available} = 0.62 \text{ m}$$

★ Choice of material

As the fluid is acidic, with a temperature of 60°C and a pH = 2.5, we have chosen a **stainless steel X2CrNiMo 17-12-2** pump.

★ Pump selection

With a HMT of 18 m, a flow rate of 120 m³ /h and a speed of 1450 rpm, the diagram gives us, by projection, the pump :

125 - 100 CPX 250

★ Power calculation

❖ Hydraulic pump power

Subscribe to DeepL Pro to edit this document.
Visit www.DeepL.com/pro for more information.

$\rho = 1.07 \cdot 10^3 \text{ kg/m}^3$; HMT= 18 m ; $Q = 120 \text{ m}^3 / \text{h}$; $g = 9.81 \text{ m/s}$.

AN: $P_{\text{hyd}} = 6,121.44 \text{ W}$ or $P_{\text{hyd}} = 6.12 \text{ kW}$.

Table 9. Mechanical power of the pump

η_{pompe}	0,6	0,78	0,8
$P_{\text{méc.}} \text{ (kW)}$	10,2	7,84	7,65

To stay within the imposed power margin, we have chosen a power of 7.84 kW.

Table 10. Summary of pump features

$P_{\text{méc.}} \text{ (kW)}$	7,84
HMT (m)	18
Flow rate (m^3 / h) ³	120
Speed (rpm)	1450
Yield η	78%

❖ Drive motor power

Knowing the power absorbed by the pump, we obtain the coefficient to be applied by projection on the curve to obtain the corresponding motor power. Thus, our installed power is:

$$P_{\text{inst}} = 122\% P_{\text{méc}} \Rightarrow P_{\text{inst}} = 9.56 \text{ kW}$$

The catalog allows us to choose a standardized power rating.

Finally, the pump motor is rated at 11 kW.

4. CONCLUSION

Sizing a hydraulic installation has always been a delicate task, especially in a complex such as Somaïr. In fact, this study enabled us to appreciate the difficulties involved in choosing pumps, calculating HMT and NPSH, and even better, creating ISOs for hydraulic circuits. In addition, delicate decisions regarding the choice of materials were made with crystal-clear explanations. The suction and discharge head losses are 0.02434 m and 0.038 m respectively. The pump's hydraulic power is 10.806 kW. In view of the 18.5 kW mechanical power required for the drive motor, we have chosen 13.51 kW in order to keep within a reasonable margin. Thus, the pump has an absorbed power of 13.51 kW with an efficiency of 80%. For the P3 2225 pump, the mechanical power is 2.4 kW, the HMT is 50 m, and the flow rate, speed and efficiency are 10 m^3 / h , 2900 rpm and 60% respectively. For the P4 5154 pumps in the discharge circuit, the

mechanical power of the pump is 6.42 KW, the HMT is 30 m and the flow, speed and efficiency are 50 m^3 / h , 2900 rpm and 68% respectively.

DISCLAIMER (ARTIFICIAL INTELLIGENCE)

Author(s) hereby declare that NO generative AI technologies such as Large Language Models (ChatGPT, COPILOT, etc) and text-to-image generators have been used during writing or editing of manuscripts.

COMPETING INTERESTS

Authors have declared that they have no known competing financial interests or non-financial interests or personal relationships that could have appeared to influence the work reported in this paper.

REFERENCES

1. Comte. Documentation: The centrifugal pump and its applications. La Houille Blanche. 1922;(1):30-33.
2. Bakelli Y. Contribution to the optimization of the sizing of an autonomous photovoltaic pumping system (Doctoral dissertation, University of Batna 2); 2012.
3. Benyerou D. Wastewater treatment and reuse.) (Messoud, D. (2014). Failure rate prediction with artificial neural networks in a wastewater treatment plant (Doctoral dissertation.); 2022.
4. Hassane Adamou Mamane Bach ir, 2012 Sizing of centrifugal pumps: case of 2013 pumps, end of cycle Engineer dissertation.
5. Khodjet-Kesba O, Kettab A, Ayadi A. Contribution to the study of the abrasive erosion of a pump. Scientific Production-Communications. 2014;1.
6. Bergeron P, Dollfus J. Influence of the nature of the mixture and hydraulic characteristics on the design and installation of liquid-solid mixture pumps. Hydraulics Days. 1959;5(2):597-605.
7. Boubrek I, Tennah N. study of the different methods of maintaining a centrifugal pump (doctoral dissertation, ibn khaldoun-tiaret-university); 2017.
8. Robert REY, Bakir F, Poulain J. Rotodynamic pumps-similitude and design of centrifugal pumps; 2012.
9. Lauro JF, Boyer A. Transfer matrix and hydroacoustic sources of a low-load centrifugal pump. La Houille Blanche. 1998;84(3-4):128-133.

10. Belaid A. Study and design of a centrifugal pump. Final dissertation With a view to obtaining the Master's degree, University of Biskra Faculty of Science and Technology Department of Mechanical Engineering); 2017.
11. Megahed M, Elsalrawy H, Essa MA. Comparative study of pumping performance of fluidyne pump with ejector and centrifugal solar pumping systems. Journal of Advanced Research in Fluid Mechanics and Thermal Sciences. 2024;119(2):91-102.
12. Pandey S, Singh RP, Mahar PS. Optimal pipe sizing and operation of multistage centrifugal pumps for water supply. Journal of Pipeline Systems Engineering and Practice. 2020;11(2):04020007.
13. Bottrell S, Bennett M, Augustin S, Thuys C, Schultz B, Horton A, Horton S. A comparison study of haemolysis production in three contemporary centrifugal pumps. Perfusion. 2014;29(5):411-416.
14. Talha A. Hydroacoustic study of a centrifugal pump and its immediate circuit by experimental analysis of unsteady pressures and speeds (Doctoral dissertation, Lille 1; 1996.
15. Sidi-Tanko OK. Dynamics of vegetation in mining area in the urban commune of Arlit. Master's Thesis, Abdou Moumouni University of Niamey Niger; 2012.
16. AMAN "Inventory of the quality of the Tarat and Izegouande aquifers Summary of chemical and radiometric analyzes available in December" (210) 1-98.
17. SRK "Environmental and Social Impact Study Report on the Madaouéla West project, Arlit, Niger final version" (2);2015.
18. Yaou Korgom F. Hydrogeological and hydrogeochemical characterization of the groundwater in the Arlit Mining Zone in Niger" Final year work; 2019.

Disclaimer/Publisher's Note: The statements, opinions and data contained in all publications are solely those of the individual author(s) and contributor(s) and not of the publisher and/or the editor(s). This publisher and/or the editor(s) disclaim responsibility for any injury to people or property resulting from any ideas, methods, instructions or products referred to in the content.

© Copyright (2024): Author(s). The licensee is the journal publisher. This is an Open Access article distributed under the terms of the Creative Commons Attribution License (<http://creativecommons.org/licenses/by/4.0>), which permits unrestricted use, distribution, and reproduction in any medium, provided the original work is properly cited.

Peer-review history:

The peer review history for this paper can be accessed here:
<https://www.sdiarticle5.com/review-history/121426>