



Design of a GPS/GSM Based Anti-theft Car Tracker System

K. O. Kadiri¹ and O. Adekoya Adegoke^{1,2*}

¹*Department of Electrical and Electronics Engineering, Federal Polytechnic, Offa, Kwara State, Nigeria.*

²*Groningen Biomolecular Sciences and Biotechnology Institute, Zernike Institute for Advanced Materials, University of Groningen, Nijenbourgh 7, 9747 AG Groningen, The Netherlands.*

Authors' contributions

This work was carried out in collaboration between both authors. Authors KOK and OAA designed the study, performed the statistical analysis, wrote the protocol, and wrote the first draft of the manuscript and managed literature searches. Authors KOK and OAA managed the analyses of the study and literature searches. Both authors read and approved the final manuscript.

Article Information

DOI: 10.9734/CJAST/2019/v34i330132

Editor(s):

(1) Dr. Chien-Jen Wang, Professor, Department of Electrical Engineering, National University of Tainan, Taiwan.

Reviewers:

(1) Luca Reggiani, Italy.

(2) Margarita Tecpoyotl Torres, Universidad Autonoma del Estado de Morelos, Mexico.

(3) A. Papazafiropoulou, Tzaneio Prefecture General Hospital of Piraeus, Greece.

(4) Mohammed About kadhim, School of Electrical and Electronics Engineering, Universiti Sains Malaysia, Malaysia.

(5) Zakaria Moudam, University Sidi Mohammed Ben Abdellah Fez, Morocco.

Complete Peer review History: <http://www.sdiarticle3.com/review-history/18707>

Review Article

Received 05 February 2015

Accepted 21 August 2015

Published 04 April 2019

ABSTRACT

This work is a SMS (Short Message Service) based tracking system, that uses a Global Positioning System (GPS) and GSM module which is installed in a secret part of the vehicle and is in charge of tracking the vehicle and sending the location of the vehicle in terms of coordinates to the GSM (Global System for Mobile communication) module. The GSM module receives the coordinates via SMS in which the information is sent to the owner of the vehicle or the police and the vehicle's position can be located in a map with the aid of the Google Maps application. This work implements the foundation of GPS, GSM, and all other embedded systems, with the use of their concepts to produce a vehicle tracking device that is cheaper and more effective than other tracking device in the market today.

*Corresponding author: E-mail: adekokeadekoyaoluwaseun@gmail.com;

Keywords: SMS; GPS; GSM; Google maps.

1. INTRODUCTION

Global System for Mobile communication (GSM) is a cellular network that mobile phones use to acquire connectivity in their immediate vicinity. These networks operate in different frequency ranges, mainly between 900 MHz and 1800 MHz; it uses a narrowband variation of Time Division Multiple Access (TDMA), which allows eight simultaneous calls on the same radio frequency. Short Message Service (SMS) is a protocol for sending and receiving text messages over GSM networks. The text can comprise of words, numbers or an alphanumeric combination. A message can go up to 160 characters of text in length using GSM coding. Global Positioning System (GPS) is a satellite based navigation system made up of a network of 24 satellites placed into the orbit.

These satellites transmit coded information which allows us to identify locations on earth precisely by measuring the distance from the satellites. The Vehicle Tracking System (VTS) also uses GPS to take the location, speed, direction and time data via satellite from the Global Positioning System to the GPS + GSM receiver in a vehicle and also transmits it to a central computer connected to a private network or the internet. It is an electronic device installed in a vehicle to enable the owner or a third party to track the vehicle's location. Most of these systems combine with mobile phones through SMS to communicate the vehicle's location to a remote user. The market for GPS vehicle tracking systems is considered as one of the fastest growing markets for GPS applications. There are many levels of sophistication, but what all systems have in common is a GPS receiver and software to put the tracking results on a map. The Vehicle Tracking System has several applications such as stolen vehicle recovery, asset tracking, field service management, field sales and trailer tracking [1].

Despite the various technologies that have been introduced in recent years to deter car thefts and tracking it, it was reported that many cars were stolen yearly in the world. According to National Crime Information Center, over 1million vehicles were reported stolen, the losses were over 5\$ billion [2] several security and tracking systems are designed to assist corporations with large number of vehicles and other usage purposes. A vehicle tracking system can minimize the cost

and effort of employees to finish road assignments within a minimal time. Besides, assignments can be scheduled in advanced based on current vehicles location. Therefore, vehicle tracking system is essential to large enterprises to meet the varying requirements of customers and to improve the productivity [3].

However, there are still some security gaps where these technologies neither prevent a vehicle from theft, assist to recover it nor allow the users to know the status of their vehicles. They don't allow the owner to communicate with the vehicle online, even if the owner is certain that his vehicle was stolen. The system designed in this work, uses the GPS module for determination of the exact location of stolen vehicles. This system is an integration of several modern communication technologies. To provide location and time information anywhere on Earth, the Global Positioning System (GPS) is commonly used as a space-based global navigation satellite system [4].

The location information provided by GPS systems can be visualized using Google Earth. In wireless data transporting, GSM and SMS technology is a common feature with all mobile network service providers [5]. Utilization of SMS technology has become popular because it is an inexpensive, convenient and accessible way of transferring and receiving data with high reliability [6]. Automatic Vehicle Location (AVL) is an advanced method used to track and monitor any remote vehicle equipped with a software unit that receives and transfers signals through GPS satellite. AVL is a combination of Global Positioning System (GPS) and Geographic Information System (GIS) that provides actual geographic real time position of each vehicle. The entire transmission mechanism of AVL setup depends on GPS satellite, a receiver on the vehicle, a radio system and PC based tracking software for dispatch. The radio communication system is generally the same as cellular phone network. The two most common AVL systems are like GPS based and Signpost based. The Signpost-based AVL system was used earlier but with the development of modern satellites GPS used technology is more used now. For the applications which require real time location information of the vehicle, Automatic Vehicle Location system is used that can transmit the location information in real time. Real time vehicular tracking system incorporates a

hardware device installed in the vehicle (In-Vehicle Unit) and a remote Tracking server [7].

The information is transmitted to Tracking server using Radio Frequency RF transmitter if the distance between tracking sever and vehicle to be track is less. Tracking server also has RF receiver that receives vehicle location information and stores this information in database. Geo-location, position location and radiolocation are terms that are widely used today to indicate the ability to determine the location of a mobile station. Location usually implies the coordinates of the mobile station that may be in two or three dimensions, and usually include information such as the latitude and longitude where the mobile station is located. Vehicle tracking device is an outdoor geo-location application in which vehicle can be located using GPS while traveling on the road. Initially vehicle tracking systems developed for vehicle were passive tracking system. In passive tracking system a hardware device installed in the vehicle store GPS location, speed, heading and a trigger event such as key on/off, door open/closed. When vehicle returns to a specific location device is removed and data downloaded to computer.

Passive systems weren't useful to track consumer's vehicle for theft prevention. Real time tracking system was required that can transmit the collected information about the vehicle after regular intervals or at least could transmit the information when required by monitoring station. Active systems were developed that transmit vehicle's data in real time via cellular or satellite networks to a remote computer or data center. Many vehicle systems that are in use now days are some form of

Automatic Vehicle Location (AVL). It is a concept for determining the geographic location of a vehicle and transmitting this information to a remotely located server [8]. The location is determined using GPS and transmission mechanism could be a satellite, terrestrial radio or cellular connection from the vehicle to a radio receiver, satellite or nearby cell tower. Other options for determining actual location, for example in environments where GPS illumination is poor, are dead reckoning, i.e. inertial navigation or active RFID systems or cooperative RTLS systems. After capture, the tracking data can be transmitted using any choice of telemetry or wireless communications systems. GSM is the most common used service for this purpose [9].

2. HARDWARE DESIGN

Hardware framework for tracking system is shown in Fig. 1. System contains high Performance ARM controller, a GPS, and GSM modem and overall system reside into a vehicle. A tracking system will provide effective real time vehicle location reporting and it will inform where your vehicle is and where it has been, how longer it has been there.

Microcontroller unit form the heart of tracking unit, which acquires and process the position data from the GPS module. The GPS receiver of vehicle terminal receives and resolves the navigation message broadcasted by GPS position satellites, computes the longitude and latitude of vehicle coordinates, transforms it into the GSM message form by GSM communication controller, and sends the message to monitoring center via the GSM network.

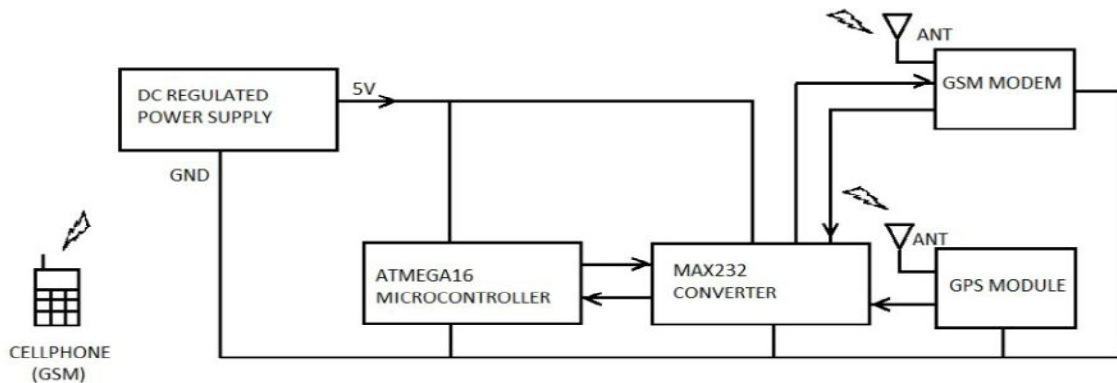

Fig. 1. Block diagram of vehicle tracking device

3. GSM HARDWARE

A GSM module as shown in Fig. 2 is a specialized type of modem which accepts a SIM card, and operates over a subscription to a mobile operator, just like a mobile phone. From the mobile operator perspective, a GSM modem looks just like a mobile phone. A wireless modem behaves like a dial-up modem. The main difference between them is that a dial-up modem sends and receives data through a fixed telephone line while a wireless modem sends and receives data through radio waves. From variety of GSM Module, the SIM300 module is used. The SIM 300 is a Trainband GSM solution in a compact plug-in module integrated with a SIM card holder. Featuring an industry-standard interface, the SIM300 delivers GSM 900/1800/1900 MHz performance for Voice, SMS, and Data in a small form factor with low power consumption.



Fig. 2. GSM module

4. GPS RECEIVER MODULE

GPS receivers are composed of an antenna, tuned to the frequencies transmitted by the satellites which are monitored by the channels, receiver-processors, and a highly stable clock (often a crystal oscillator). GPS receivers may include an input for differential corrections, using the RTCM SC-104 format. This is typically in the form of an RS-232 port at 4,800 bit/s speed. Data is actually sent at a much lower rate, which limits the accuracy of the signal sent using RTCM.

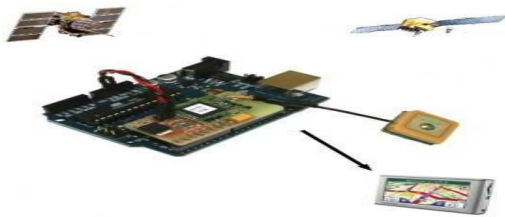

Fig. 3. GPS receiver

The GPRMC is the sentence that is been used in this work for location. It shows the LATTITUDE & LONGITUDE locations as shown thus:

\$GPRMC,255736,A,4788.47,N,13456.18,W,000.6,097.7,191298,030.5,E*69,

Table 1 gives the explanation of the GPRMC

Table 1. GPRMC explanation

2557336	Time of fix 25:57:36 UTC
A	Navigation receiver warning A=OK, V= warning
4788.47,N	Latitude 47degree. 88.47 min North
13456.18,W	Longitude 134 degree. 56.18 min West
000.6	Speed over ground,Knots
097.7	Course Made Good, True
191298	Date of fix 19 December 1998
030.5,E	Magnetic variation 30.5 degree East
*69	Mandatory Checksum

5. MICROCONTROLLER

The main part of hardware design is the microcontroller, ATmega16 microcontroller is chosen for our system because is a low-power, high-performance Complementary metal-oxide-semiconductor (CMOS) 8-bit microcontroller with 8 K bytes of in-system programmable Flash memory. Its standard features are 8 K bytes of Flash, 256 bytes of RAM, 32 I/O lines, Watchdog timer, two data pointers, three 16-bit timer/counters, a six-vector two-level interrupt architecture, a full duplex serial port, on-chip oscillator, and clock circuitry. It is designed with static logic for operation down to zero frequency and supports two software selectable power saving modes. The Idle Mode stops the Central Processing Unit (CPU) while allowing the Random Access memory (RAM), timer/counters, serial port, and interrupt system to continue functioning.

The circuit design for the overall system is shown in Fig. 4.

The flow chart for the system is shown in Fig. 5.

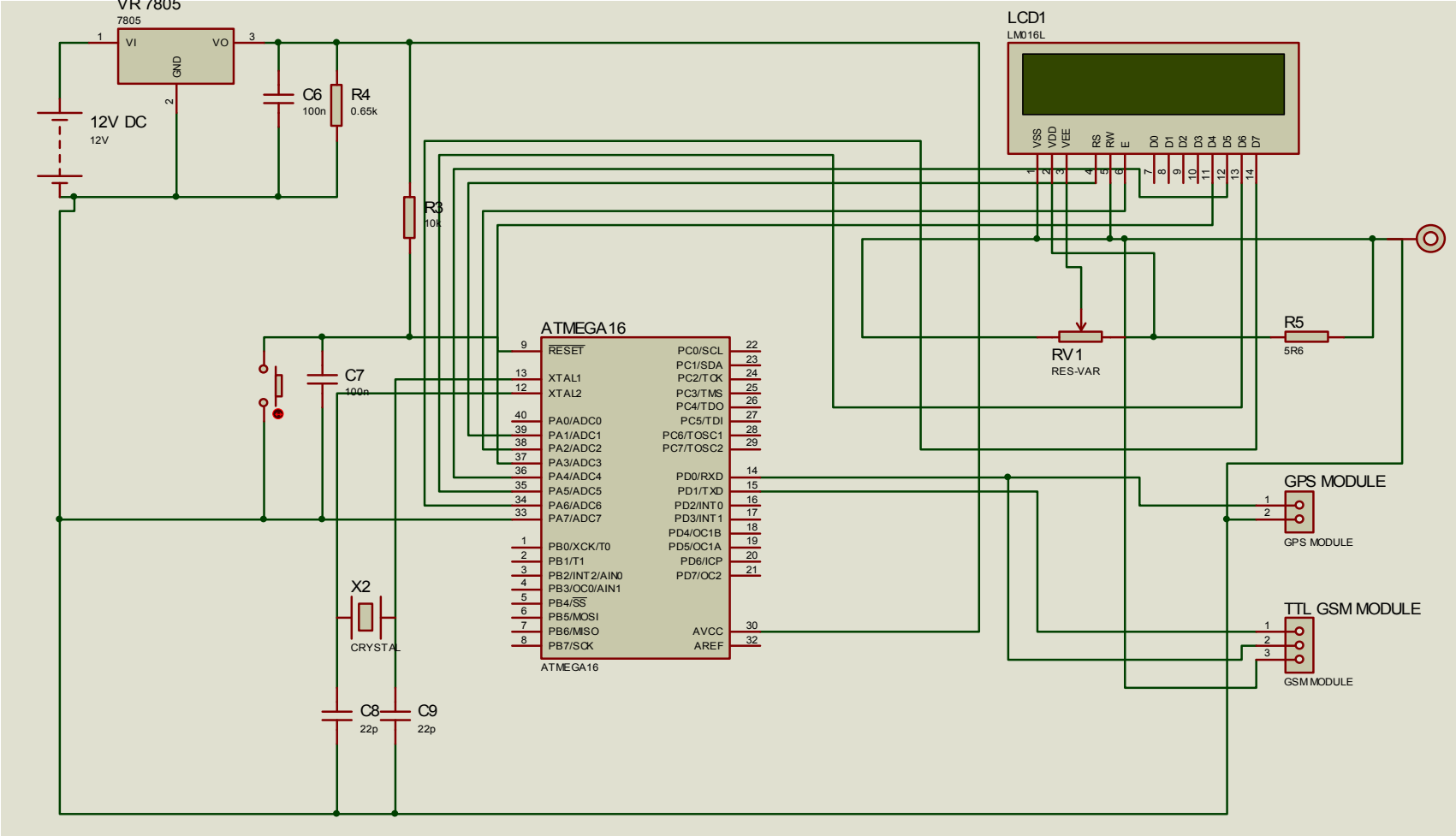

Fig. 4. Circuit diagram of GSM/GPS vehicle tracking system

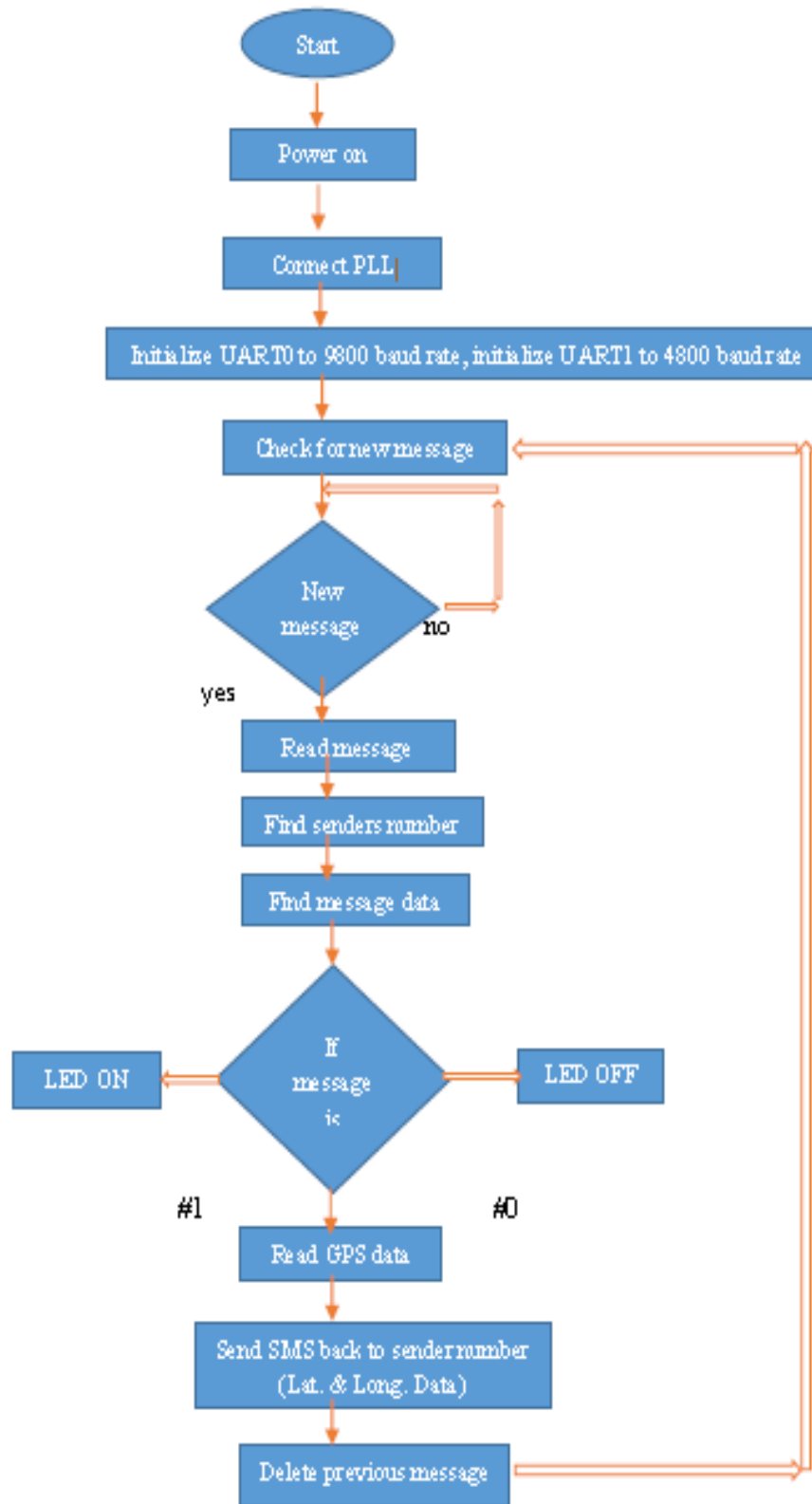

Fig. 5. Flow chart diagram for vehicle tracking system

6. RESULTS AND DISCUSSIONS

Atmega32 microcontroller is a programmable IC, which needs to be programmed to suit the design. The source code was first compiled on the notepad and then test ran on Multism Simulator. Proper connection was given to the code during compilation in order to avoid any logic errors. The hex file was then generated and transferred to the chip with the aid of a programmer. All the ICs were tested separated on a bread board to make sure they work properly. The whole circuit was also tested on the bread board to make sure it was design correctly. During construction, each section was tested as it was built to make sure the connections were done correctly before going onto the next section. This was done by applying the correct logic signals to the ICs and observing the output.

7. RESULTS ANALYSIS

In this work ATmega16 microcontroller is used for interfacing to various hardware peripherals. The current design is an embedded application, which will continuously monitor a moving Vehicle and report the status of the Vehicle on demand. For doing so an ATmega16 microcontroller is interfaced serially to a GSM Modem and GPS Receiver. A GSM modem is used to send the position (Latitude and Longitude) of the vehicle from a remote place. The GPS modem will continuously give the data i.e. the latitude and longitude indicating the position of the vehicle. The GPS modem gives many parameters as the output, but only the NMEA data coming out is read. The hardware interfaces to microcontroller, GSM modem and GPS Receiver.

When the request by user is sent to the number at the modem, the system automatically sends a return reply to that mobile indicating the position of the vehicle in terms of latitude and longitude from this information we can track our vehicles

8. CONCLUSION

The work has been successfully designed and implemented for the "GPS/SMS BASED ANTHITHEFT VEHICLE TRACKING SYSTEM". It has been developed by integrating features of all the hardware components used. Presence of every module has been reasoned out and placed carefully thus contributing to the best working of the unit.

Secondly, using highly advanced IC's and with the help of growing technology the work has been successfully implemented and tested.

Finally it's concluded that GPS and GSM based Security System add a huge for the rapid growth of Technology.

9. FUTURE WORKS

Ideally, this work could be made more convenient and secure with the use of satellite modems instead of GSM modules as tracking device as the system may fail when there is no network coverage. This design can be made more enhanced in future to support camera, handset phone / hands free, mobile data display, also PC based stand alone software.

In this work the security system is based on embedded control which provides security against theft. GPS/GSM vehicle tracker can be effectively used by individual society and basically by the police in order to trace the stolen vehicle. This project does not indicate the time when the event takes place, further research can look into this. A reset button is used as sensor for monitoring the door because it is expensive, further research can incorporate this. A fuel sensor that will monitor the status of the fuel can also be implemented in further research.

COMPETING INTERESTS

Authors have declared that no competing interests exist.

REFERENCES

1. Wankhade PP, Dahad SO. Real Time Vehicle Locking and Tracking System using GSM and GPS Technology - An Anti-theft System. (IJTES); 2004.
2. National research council I (U.S), committee on the future of the Global positioning system; National Academy of Public Administration. 1995;1:6
3. Micheal A Al-Taee, Khader OB, Al-Saber NA. Remote monitoring of vehicle diagnostics and location using a smart box with global positioning system and general packet radio service, in Proc. IEEE/ACS AICCSA, Amman. 2007;385-388.
4. James E Marca, Rindt CR, Mcnally M, Doherty ST. A GPS enhanced in-vehicle extensible data collection unit. Inst. Transp. Studies. Univ. California, Irvine, CA, Uci. 2000;4:1-9.

5. Hapsari T, Syamsudin EY, Pramana I. Design of vehicle position tracking system using short message services and its implementation on FPGA, in Proc. Conference on Asia South Pacific Design Automation, Shanghai, China; 2005.
6. Hsiao WCM, Chang SKJ. The Optimal Location Update Strategy of Cellular Network Based Traffic Information System, in Proc. Intelligent Transportation Systems Conference, Toronto. 2006;248-253.
7. Maurya K, Singh M, Jain N. Real time vehicle tracking system using GSM and GPS Technology- An Anti-theft Tracking System (IJECSE); 2000.
8. GSM Multiple Access Scheme, Available:<http://www.eecg.toronto.edu/~nazizi/gsm/ma/>
William Stallings Data and Computer Communications 7th Edition: Chapter 9 Spread Spectrum.
Available:<http://juliet.stfx.ca/~lyang/csci-465/lectures/09-SpreadSpectrum-new.ppt>
9. Jörg Eberspächer, Hans-Jörg Vögel. GSM switching, services and Protocols. John Wiley and Sons, New York; 1999.

© 2019 Kadiri and Adegoke; This is an Open Access article distributed under the terms of the Creative Commons Attribution License (<http://creativecommons.org/licenses/by/4.0>), which permits unrestricted use, distribution, and reproduction in any medium, provided the original work is properly cited.

Peer-review history:
The peer review history for this paper can be accessed here:
<http://www.sdiarticle3.com/review-history/18707>